

Commercial Automatic Ice Maker

Instruction Manual

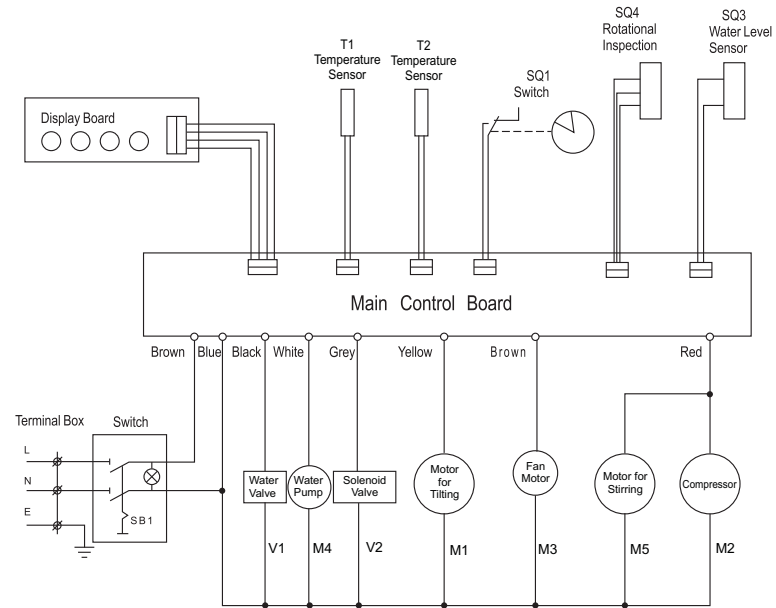

Thank you for selecting our Automatic Ice-Maker!
To ensure the proper operation of this ice maker, please read the instruction manual carefully before use and please keep it ready to hand at the product!

Diagram



CONTENT

Introduction	1
Safety Tips	1
Structure	2
Accessory	2
Control Panel	3
Installation	3
Operation	3
Cleaning and Maintenance	4
Technical Parameters	5
Troubleshooting	5
Diagram	7

Introduction

Please take a few moments to carefully read through this manual. Correct maintenance and operation of this machine will provide the best possible performance.

Safety Tips

- Position on a flat, stable surface.
- A service agent/qualified technician should carry out installation and any repairs if required. Do not remove any components or service panels on this product.
- DO NOT immerse in water, or use steam/jet washers to clean the unit.
- DO NOT cover the appliance when it is operating.
- DO NOT place the appliance near flammable materials and be sure fine ventilation.
- DO NOT lay the cable over carpets or heat insulations. Do not cover the cable. Keep away the cable from operating range and do not dunk it into water.
- Always carry, store and handle the appliance in a vertical position.
- Never tilt the appliance more than 45° from the vertical.
- ONLY use drinking or potable water when making ice cubes.
- Ensure the water pressure of the connected water supply is between 1kg/cm² to 8kg/cm² (14.7-117psi).
- The device is to be used indoors only.
- Keep all packaging away from children. Dispose of packaging in accordance to the regulations of local authorities.
- If the power cord is damaged, it must be replaced by a recommended qualified technician in order to avoid a hazard.
- The separate three-pole socket should be used and it must be grounded.
- The rated capacity of wire should be over 6A, but for the IM-80, it should be over 10A, the section area of the wire is 0.75mm². But for the IM-80, it should be over 1.0mm². The wire could be consisted by single ply or multiplies.

Problem	Possible Cause	Suggested Solution
• Device dose not work (Without any lights come on)	• Power supply is interrupted • Power supply voltage is not correct	• Check the power supply • Cut off the power supply
• Device dose not work (Only switch light come on)	• Power supply voltage is not correct • PCB board damaged	• Cut off the power supply • Replace it
• Device dose not work (The ice full light come on)	• Ice full occur • Ambient temperature is below 6°C	• Remove the ice cubes from basket • Keeping the ambient temperature is more than 7°C , restart it
• Device dose not work (ice full and fault flash together)	• Ice full sensor damaged or does not connected	• Replace or connect this sensor
• Device dose not work (fault light flash)	• condenser sensor damaged or does not connected	• Replace or connect this sensor
Water low and ice full flash together or the fault flash rapidly	• Refrigerant leaked • Compressor does not run • Ambient temperature is below 6°C	• Check and recharge • Compressor damaged or the ambient temperature is higher than 43°C • Keeping the ambient temperature over 7°C , restart it
• Fault, water low, ice full three lights flash slowly	• the HALL sensor is not in correct position or damaged. • paddle motor damaged	• adjust the position or replace it. • replace it
• Only the fault light flash rapidly (after working a period.)	• Turn ice motor damaged • Micro-switches do not function. • Water box broken • Water box was blocked by ice cubes	• Replace it • Replace or adjust position again • Replace it • Remove the ice cubes
• Device stop after 2 minutes or more. (The water low light flashes)	• Without water in water supply source • Water inlet valve damaged or does not connect • water level sensor not in correct position	• waiting for water supplying • Check valve connecting or replace it.
• Water low light always come on	• without water supply for more then 24 hours	• stop the machine and restart it if water supply is ready
• Ice cubes stick in the water box	• The electric valve does not function • Some ice remain in the water box	• Check the valve electrical connecting or replace it • Stop the machine and move it
• No ice making no fault indication	• The electric valve was leak • Compressor does not run	• Replace it. • Ask service
• Ice cubes are not very equal	• Refrigerant leak	• Recharge it

Technical Parameters

Model	Ice making capacity (Kg/24h)	Power Input (W)	Ice Storage (Kg)	Dimensions (mm)
IM-25	25	240	7	398X542X682
IM-50	50	380	13	548X611X823
IM-80	80	580	13	548X611X823

The specifications are subject to be changed without notice.
Please check the nameplate for sure.

Troubleshooting

Note: If any trouble occurs, please wait till the machine stop automatically; Follow list will be helpful for you to know the machine troubles, but only authority person can open and check or repair the machine!

- The **RUN** light does not come on when switch on the machine at first time, it will light when the compressor is running.
- This ice maker has an advantage self-checking function, every fault will be displayed in the display panel with the different lights flash.

Structure

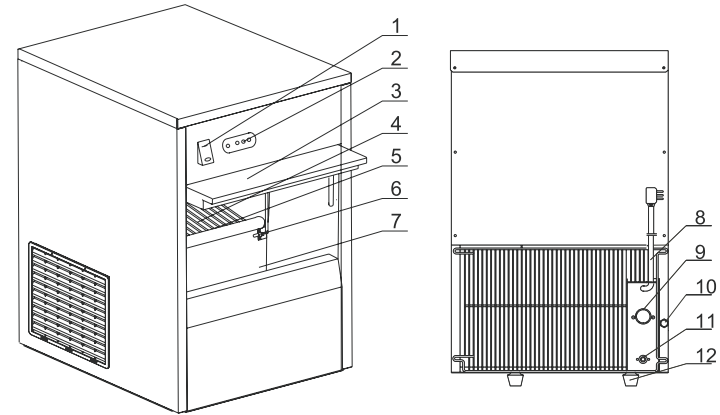

- | | | |
|-----------------------|---------------------------|-------------------------|
| 1 Switch | 2 Display Panel | 3 Slide Door |
| 4 Shelf | 5 Water Cabinet | 6 Ice Full Sensor |
| 7 Ice Storage Cabinet | 8 Power Cord | 9 Water Inlet Connector |
| 10 Screw for Drainage | 11 Water Outlet Connector | 12 Foot |

Accessory

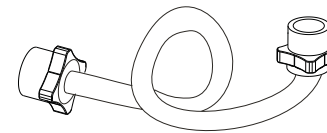

Water Inlet Tube

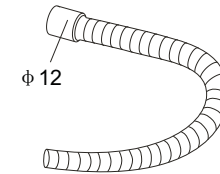

Water Drainage Pipe



Sealing Washer



Ice Spoon

Control Panel



Installation

1. Remove the appliance from the packaging and remove the protective film from all surfaces.
2. Remove the Ice Spoon, Water Inlet Tube, Water Drainage Pipe and Sealing Washers from the ice storage cabinet.
3. Place the device on top of an even and safe surface which supports the weight of the device.
4. Choose a surface where the ice maker is not exposed to direct sunlight, or close to a direct source of heat such as a cooker, oven or radiator.
5. When positioning the ice maker, maintain a distance of 20cm (7 inches) between the appliance and walls or other objects for ventilation. Increase this distance if the obstacle is a heat source.
6. Position the device in a way so that the power plug is always accessible.
7. Set up the device near water supply connection.
8. If necessary, adjust the screw legs of the ice maker to make it level. The efficiency of the ice maker can be reduced if the appliance is unevenly located.
9. Connect one end of the Water Drainage Pipe to the water outlet connector on the rear of the ice maker.
10. Attach the other end of the pipe to a plumbed in stand waste pipe or container suitable for collecting waste water.
11. Connect one end of the Water Inlet Tube to the 3/4" screw type connector of the water tap so as to get the drinkable tap water. Be sure to put sealing washers in both ends of the water inlet tube before connecting.
12. Connect the other end of the inlet tube to the water inlet connector.

Operation

Note: If using the ice maker for the first time (or after a period of inactivity) please

discard the first two batches of ice. This cleans the internal systems of the ice maker.

1. Connect the device to a grounded single power socket.
 2. Press the Power switch to the ON position [I]. The Switch light illuminates and the appliance start to work. The first 5 minutes is used for the self-inspection of the ice maker. Then it will begins the ice making process.
 3. As soon as the ice storage cabinet is full, the panel display indicates "ICE FULL", and the ice production stops automatically. Production resumes once ice has been removed from the cabinet.
 4. If water supply is insufficient, the panel displays "WATER LOW", and the ice production stops automatically.
 5. If any error or failure occurs, the panel display indicates "FAULT" and the ice production stops.
 6. Switch off the device and disconnect it from power supply (Pull the power plug!), when it is not in use.
 7. Do not switch on the device immediately after it stops automatically (caused by insufficient water supply, ice storage cabinet too full, current interruption). Wait at least 3-5 minutes before restart it in order to avoid damages of the compressor.
- NOTE: If the device is not used for a longer period of time, drain the water from the water tank via the drain screw at the back of the device (some model no drain screw). Wipe dry the water tank using a dry cloth.

Cleaning and Maintenance

- Always switch off and disconnect the power supply before cleaning.
 - Warm, soapy water is recommended for cleaning. Cleaning agents may leave harmful residues.
- DO NOT wash the base unit, instead wipe the exterior with a damp cloth.
- Check regularly the connectors of the water inlet and outlet tubes and drain the little surplus water that may leak.
 - If the ice make will be unused for a long period, please switch off the power switch and wipe the inner liner of the ice storage container with a clean rag.
 - When plugging or unplugging, the plug should be held by hand and the wires should not be dragged heavily.